

ICS 29.060.20

English Version

Electric cables for photovoltaic systems (BT(DE/NOT)258)

Câbles électriques pour systèmes photovoltaïques
(BT(DE/NOT)258)

Kabel und Leitungen - Leitungen für Photovoltaik Systeme
(BT(DE/NOT)258)

This European Standard was approved by CENELEC on 2014-10-27. CENELEC members are bound to comply with the CEN/CENELEC Internal Regulations which stipulate the conditions for giving this European Standard the status of a national standard without any alteration.

Up-to-date lists and bibliographical references concerning such national standards may be obtained on application to the CEN-CENELEC Management Centre or to any CENELEC member.

This European Standard exists in three official versions (English, French, German). A version in any other language made by translation under the responsibility of a CENELEC member into its own language and notified to the CEN-CENELEC Management Centre has the same status as the official versions.

CENELEC members are the national electrotechnical committees of Austria, Belgium, Bulgaria, Croatia, Cyprus, the Czech Republic, Denmark, Estonia, Finland, Former Yugoslav Republic of Macedonia, France, Germany, Greece, Hungary, Iceland, Ireland, Italy, Latvia, Lithuania, Luxembourg, Malta, the Netherlands, Norway, Poland, Portugal, Romania, Slovakia, Slovenia, Spain, Sweden, Switzerland, Turkey and the United Kingdom.



European Committee for Electrotechnical Standardization
Comité Européen de Normalisation Electrotechnique
Europäisches Komitee für Elektrotechnische Normung

CEN-CENELEC Management Centre: Avenue Marnix 17, B-1000 Brussels

Contents	Page
Foreword	4
Introduction	5
1 Scope	6
2 Normative references	6
3 Terms and definitions	7
4 Rated voltage	8
5 Requirements for the construction of cables	8
5.1 Conductors	8
5.2 Insulation	8
5.3 Sheath	9
6 Marking	10
6.1 General	10
6.2 Indication of origin	10
6.3 Code designation	10
6.4 Nominal cross-sectional area of conductor	10
6.5 Continuity of marking	10
6.6 Use of the name CENELEC	10
6.7 Additional requirements	11
7 Requirements for completed cables	11
7.1 General	11
7.2 Electrical tests	11
7.3 Non electrical tests	12
Annex A (normative) Guide to use – Use of cables for PV systems	20
Annex B (normative) Requirements for insulation and sheathing materials	24
Annex C (normative) Cold impact test	26
Annex D (normative) Dynamic penetration test	27
Annex E (normative) Weathering/UV resistance test	28
Bibliography	29
Figures	
Figure 1 – Example of the marking as used on the outer sheath of the cable	10
Figure D.1 — Arrangement for dynamic penetration test.....	27
Tables	
Table 1 — Dimensional and insulation resistance values	14
Table 2 — Tests for cables to EN 50618	15
Table A.1 — Intended use of cables for PV systems (environmental conditions)	21
Table A.2 — Recommended use of cables for PV systems	22
Table A.3 — Current carrying capacity of PV cables	22

Table A.4 — Current rating conversion factors for different ambient temperatures.....	23
Table B.1 — Requirements for insulation and sheathing materials	24
Table C.1 — Parameters for cold impact test	26

Foreword

This document (EN 50618:2014) has been prepared by CLC/TC 20 "Electric cables".

The following dates are fixed:

- latest date by which this document has to be implemented at national level by publication of an identical national standard or by endorsement (dop) 2015-10-27
- latest date by which the national standards conflicting with this document have to be withdrawn (dow) 2017-10-27

Attention is drawn to the possibility that some of the elements of this document may be the subject of patent rights. CENELEC shall not be held responsible for identifying any or all such patent rights.

This standard covers the Principle Elements of the Safety Objectives for Electrical Equipment Designed for Use within Certain Voltage Limits (LVD - 2006/95/EC).

Introduction

This standard specifies cables for use in Photovoltaic (PV) Systems, in particular for installation at the Direct Current (d.c.) side. These cables are suitable for permanent outdoor use for many years under variable demanding climate conditions. Relatively stringent requirements are set for these products in line with the expected harsh usage conditions.

During the writing of this standard the joint work of TC 64 (Electrical installations and protection against electric shock) and TC 82 (Solar Photovoltaic Energy Systems) on the design and installation of PV systems has been taken into account.

1 Scope

This European Standard applies to low smoke halogen-free, flexible, single-core power cables with cross-linked insulation and sheath. In particular for use at the direct current (d.c.) side of photovoltaic systems, with a nominal d.c. voltage of 1,5 kV between conductors and between conductor and earth.

The cables are suitable to be used with Class II equipment.

The cables are designed to operate at a normal maximum conductor temperature of 90 °C, but for a maximum of 20 000 hours a max. conductor temperature of 120 °C at a max. ambient temperature of 90 °C is permitted.

NOTE The expected period of use under normal usage conditions as specified in this standard is at least 25 years.

2 Normative references

The following documents, in whole or in part, are normatively referenced in this document and are indispensable for its application. For dated references, only the edition cited applies. For undated references, the latest edition of the referenced document (including any amendments) applies.

EN 50289-4-17, *Communication cables – Specifications for test methods – Part 4-17: Test methods for UV resistance evaluation of the sheath of electrical and optical fibre cable*

EN 50395:2005, *Electrical test methods for low voltage energy cables*

EN 50396:2005, *Non electrical test methods for low voltage energy cables*

EN 50525-1:2011, *Electric cables – Low voltage energy cables of rated voltages up to and including 450/750 V (U₀/U) – Part 1: General requirements*

EN 50565-1:2014, *Electric cables – Guide to use for cables with a rated voltage not exceeding 450/750 V (U₀/U) – Part 1: General guidance*

EN 60068-2-78, *Environmental testing – Part 2-78: Tests – Test Cab: Damp heat, steady state (IEC 60068-2-78)*

EN 60216-1, *Electrical insulating materials – Thermal endurance properties – Part 1: Ageing procedures and evaluation of test results (IEC 60216-1)*

EN 60216-2, *Electrical insulating materials – Thermal endurance properties – Part 2: Determination of thermal endurance properties of electrical insulating materials – Choice of test criteria (IEC 60216-2)*

EN 60228:2005, *Conductors of insulated cables (IEC 60228:2004)*

EN 60332-1-2:2004, *Tests on electric and optical fibre cables under fire conditions – Part 1-2: Test for vertical flame propagation for a single insulated wire or cable – Procedure for 1 kW pre-mixed flame (IEC 60332-1-2:2004)*

EN 60811-401, *Electric and optical fibre cables – Test methods for non-metallic materials – Part 401: Miscellaneous tests – Thermal ageing methods – Ageing in an air oven (IEC 60811-401)*

EN 60811-403, *Electric and optical fibre cables – Test methods for non-metallic materials – Part 403: Miscellaneous tests – Ozone resistance test on cross-linked compounds (IEC 60811-403)*

EN 60811-404, *Electric and optical fibre cables – Test methods for non-metallic materials – Part 404: Miscellaneous tests – Mineral oil immersion tests for sheaths (IEC 60811-404)*

EN 60811-501, *Electric and optical fibre cables – Test methods for non-metallic materials – Part 501: Mechanical tests – Tests for determining the mechanical properties of insulating and sheathing compounds (IEC 60811-501)*

EN 60811-503, *Electric and optical fibre cables – Test methods for non-metallic materials – Part 503: Mechanical tests - Shrinkage test for sheaths (IEC 60811-503)*

EN 60811-504, *Electric and optical fibre cables – Test methods for non-metallic materials – Part 504: Mechanical tests - Bending tests at low temperature for insulation and sheaths (IEC 60811-504)*

EN 60811-505, *Electric and optical fibre cables – Test methods for non-metallic materials – Part 505: Mechanical tests - Elongation at low temperature for insulations and sheaths (IEC 60811-505)*

EN 60811-506, *Electric and optical fibre cables – Test methods for non-metallic materials – Part 506: Mechanical tests - Impact test at low temperature for insulations and sheaths (IEC 60811-506)*

EN 60811-507, *Electric and optical fibre cables – Test methods for non-metallic materials – Part 507: Mechanical tests - Hot set test for cross-linked materials (IEC 60811-507)*

EN 61034-1, *Measurement of smoke density of cables burning under defined conditions – Part 1: Test apparatus (IEC 61034-1)*

EN 61034-2, *Measurement of smoke density of cables burning under defined conditions – Part 2: Test procedure and requirements (IEC 61034-2)*

EN 62230:2007, *Electric cables – Spark-test method (IEC 62230:2006)*

HD 60364-5-52:2011, *Low-voltage electrical installations – Part 5-52: Selection and erection of electrical equipment – Wiring systems*

HD 60364-7-712, *Electrical installations of buildings – Part 7-712: Requirements for special installations or locations – Solar photovoltaic (PV) power supply systems (IEC 60364-7-712)*

3 Terms and definitions

For the purposes of this document, the following terms and definitions apply.

3.1

type tests (T)

tests required to be made before supplying a type of cable covered by this standard on a general commercial basis, in order to demonstrate satisfactory performance characteristics to meet the intended application

Note 1 to entry: Type tests are of such a nature that, after they have been made, they need not be repeated unless changes are made in the cable materials, design or type of manufacturing process which might change the performance characteristics.

3.2

sample tests (S)

tests made on samples of completed cable, or components taken from a completed cable adequate to verify that the finished product meets the design specifications

3.3

routine tests (R)

tests made on all production cable lengths to demonstrate their integrity

3.4

halogen-free material

material complying with the requirements of Annex B of EN 50525-1:2011

4 Rated voltage

The cables specified in this standard are in particular designed for use at the direct current (d.c.) side of photovoltaic-systems, with a nominal d.c. voltage of 1,5 kV between conductors as well as between conductor and earth.

The cables have a rated voltage of 1,0/1,0 kV when used in alternating current (a.c.) systems.

Annex A provides further guidance on voltage ratings.

5 Requirements for the construction of cables

5.1 Conductors

5.1.1 Material

The conductors shall be copper, and in accordance with EN 60228.

The wires of conductors shall be tin coated. The wires shall be covered with a continuous layer of tin coating.

There shall be no visible gaps in the continuous layer, when examined with normal or corrected vision.

5.1.2 Construction

The class of the conductor shall be class 5 in accordance with EN 60228.

The maximum diameters of the wires in the conductor shall be in accordance with EN 60228.

5.1.3 Separator between conductor and insulation

It is permitted to use a separating tape between the conductor and the insulation.

5.1.4 Check of construction

Compliance with the requirements of 5.1.1, 5.1.2 and 5.1.3, including the requirements of EN 60228, shall be checked by inspection and by measurement.

5.1.5 Electrical resistance

The resistance of each conductor at 20 °C shall be in accordance with the requirements of EN 60228 for a metal coated Class 5 conductor.

Compliance shall be checked by the test given in Clause 5 of EN 50395:2005.

5.2 Insulation

5.2.1 Material

The insulation material shall be cross-linked and fulfil the requirements as specified in Table B.1 in Annex B.

5.2.2 Application to the conductor

The insulation shall be applied by extrusion, such that it fits closely on the conductor, but it shall be possible to remove it without damage to the insulation itself, to the conductor or to the tin coating. It is permitted to apply the insulation in a single layer, or in a number of coherent layers. Where more than one layer is used, all testing shall be carried out on the complete insulation as though it were a single layer.

NOTE Insulation applied in more than one layer does not conform to the definition of "Double insulation" given, for instance, in HD 60364.

Compliance shall be checked by inspection and by manual test.

5.2.3 Thickness

For each piece of insulation, the average of the measured values, rounded to 0,1 mm, shall be not less than the specified value for each size shown in Table 1.

The smallest value measured shall not fall below 90 % of the specified value by more than 0,1 mm, i.e.:

$$t_m \geq 0,9t_s - 0,1$$

where

t_m is the minimum insulation thickness at any point, in millimetres;

t_s is the specified insulation thickness, in millimetres.

Compliance shall be checked using the test given in EN 50396:2005, 4.1.

5.3 Sheath

5.3.1 Material

The sheath material shall be cross-linked and fulfil the requirements as specified in Table B.1.

5.3.2 Application

The sheath shall be applied homogeneously by extrusion. It is permitted to apply the sheath in a single layer, or in a number of coherent layers. Where more than one layer is used, all testing shall be carried out on the complete sheathing as though it were a single layer.

The application of the sheath shall give the finished cable a practically circular shape.

A separator may be applied under the sheath.

5.3.3 Thickness

For each piece of sheath, the average of the measured values, rounded to 0,1 mm, shall be not less than the specified value for each size shown in Table 1.

The smallest value measured shall not fall below 85 % of the specified value by more than 0,1 mm, i.e.:

$$t_m \geq 0,85t_s - 0,1$$

where

t_m is the minimum sheath thickness at any point, in millimetres;

t_s is the specified sheath thickness, in millimetres.

Compliance shall be checked using the test given in EN 50396:2005, 4.2.

5.3.4 Colour

The sheath shall be coloured black, unless otherwise agreed between manufacturer and customer.

The colour shall be throughout the whole of the sheath.

6 Marking

6.1 General

The sheath of the cable shall be marked by printing, embossing or indenting.

6.2 Indication of origin

Cables shall be provided with an identification of origin consisting of the continuous marking of the manufacturer's name or trademark, or (if legally protected) identification number.

6.3 Code designation

Cables shall be marked with the following code designation 'H1Z2Z2-K'.

6.4 Nominal cross-sectional area of conductor

Cables shall be marked with the nominal cross-sectional area, for example '2,5 mm²'.

6.5 Continuity of marking

Each specified marking shall be regarded as continuous if the distance between the end of the mark and the beginning of the next identical mark does not exceed 550 mm.

NOTE A 'Specified Marking' is any mandatory marking covered by this standard.

Other marking, such as that required under recognized voluntary 3rd party approval schemes, may also follow the requirements of this subclause.

The diagram below shows an example of the marking as used on the outer sheath of the cable.

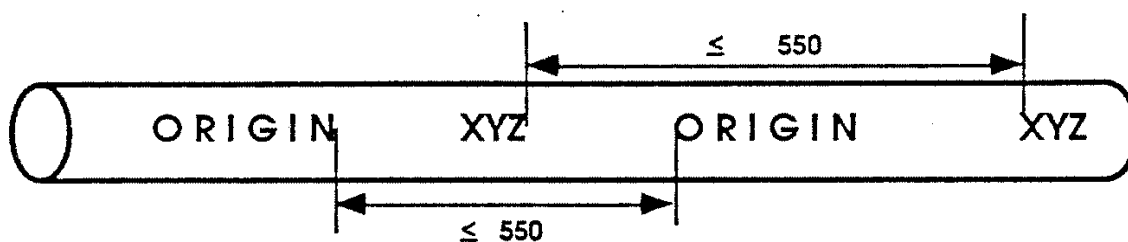

Figure 1 – Example of the marking as used on the outer sheath of the cable

6.6 Use of the name CENELEC

The name CENELEC, in full or abbreviated, shall not be marked on, or in, the cables.

6.7 Additional requirements

6.7.1 Durability

Printed markings shall be durable. Compliance with this requirement shall be checked by the test given in EN 50396:2005, 5.1.

6.7.2 Legibility

All markings shall be legible.

7 Requirements for completed cables

7.1 General

The tests to be carried out on cables specified in this standard shall be as scheduled in Table 2, which refers to the relevant clauses of the standard specifying the requirements and test methods as well as the category of each test which applies, i.e. Type Test (T); Sample Test (S) or Routine Test (R) (as defined in Clause 3).

Requirements for tests not previously specified are as given in 7.2 to 7.3.

7.2 Electrical tests

7.2.1 Voltage test on completed cable

The cable shall be tested in accordance with Clause 6 of EN 50395:2005 using the test conditions, voltages and time as stated in Table 2.

No breakdown of the insulation shall occur.

7.2.2 Check for absence of faults on the insulation or on the complete cable

The cable shall be tested for faults in accordance with EN 62230:2007, Annex A. In case checking of the insulation only is impossible, testing shall be performed on the complete cable.

No fault shall be detected.

7.2.3 Measurement of insulation resistance

The cable shall be tested in accordance with 8.1 of EN 50395:2005 at 20 °C using the test conditions as given in Table 2. The insulation resistance at 20 °C shall not be less than stated in Table 1 for the relevant conductor size.

The cable shall also be tested in accordance with 8.1 of EN 50395:2005 at 90 °C using the test conditions as given in Table 2. The insulation resistance at 90 °C shall not be less than stated in Table 1 for the relevant conductor size.

7.2.4 Long term resistance of insulation to d.c

The cable shall be tested in accordance with Clause 9 of EN 50395:2005 using the test conditions as given in Table 2.

The cable shall meet the requirements as stated in Table 2.

Discoloration of the insulation should be ignored.

7.2.5 Surface resistance of sheath

The cable shall be tested in accordance with Clause 11 of EN 50395:2005 using the test conditions as given in Table 2.

The surface resistance of the sheath shall meet the test requirements as stated in Table 2.

7.3 Non electrical tests

7.3.1 Sheath colour

The colour throughout the sheath shall be checked by visual examination and shall be in accordance with 5.3.4.

7.3.2 Sheath marking

The marking on the sheath shall comply with the requirements stated in Clause 6. They shall be checked by visual examination and measurement.

7.3.3 Overall diameters and ovality

Informative values on maximum overall diameters of the cables are given in Table 1.

Ovality of the cables shall be limited: the difference between any two values of the actual overall diameter of a sheathed cable at the same cross-section shall not exceed 15 %.

7.3.4 Compatibility

The cable shall be tested in accordance with EN 60811-401:2012, 4.2.3.4, using the test conditions as given in Table 2.

The insulation and sheath shall meet the test requirements stated in Table B.1.

7.3.5 Cold impact

The cable shall be tested in accordance with EN 60811-506 using the test conditions as given in Table 2.

The cable shall be inspected with normal or corrected vision without magnification and shall meet the test requirements as stated in Table 2.

7.3.6 Cold bending

Cables with diameters $\leq 12,5$ mm cable shall be tested in accordance with EN 60811-504 using the test conditions as given in Table 2.

The cable shall be inspected with normal or corrected vision without magnification and shall meet the test requirements as stated in Table 2.

7.3.7 Cold elongation

Cables with diameters $> 12,5$ mm cable shall be tested in accordance with EN 60811-505 using the test conditions as given in Table 2 and shall meet the requirements as stated in Table 2.

7.3.8 Ozone resistance

The cable shall be tested in accordance with EN 50396:2005, 8.1.2, using the test conditions as given in Table 2. Test Method A or B may be applied.

The cable shall be inspected with normal or corrected vision without magnification and shall meet the requirements as stated in Table 2.

Any cracks near the fixing point on the mandrel and/or near the clamps when using test strips shall be disregarded.

7.3.9 Weathering/UV resistance

The cable shall have adequate resistance to outdoor weather conditions and shall be tested in accordance with Annex E.

The cable shall meet the requirements as stated in Annex E.

7.3.10 Dynamic penetration

The cable shall be tested in accordance with Annex D.

The cable shall meet the requirements as stated in Annex D.

7.3.11 Damp heat test

The cable shall be tested in accordance with EN 60068-2-78 using the test conditions as given in Table 2.

The cable shall meet the requirements as stated in Table 2.

7.3.12 Shrinkage

The cable shall be tested in accordance with EN 60811-503 using the test conditions as given in Table 2 and shall meet the test requirements as stated in Table 2.

7.3.13 Vertical flame propagation

The cable shall be tested in accordance with EN 60332-1-2.

The complete cable shall conform to the flame propagation requirements specified in EN 60332-1-2:2004, Annex A.

7.3.14 Smoke emission

The cable shall be tested in accordance with EN 61034-2, using the apparatus specified in EN 61034-1.

The amount of smoke generated shall not exceed the minimum light transmittance value stated in Table 2.

7.3.15 Assessment of halogens

The insulation material and the sheathing material as well as any tapes that may have been used shall have an assessment of halogens in accordance with EN 50525-1:2011, Annex B, and shall meet the requirements as stated in EN 50525-1:2011, Annex B.

Table 1 — Dimensional and insulation resistance values

1	2	3	4	5	6
Number and nominal cross sectional area of conductors	Thickness of insulation Specified value	Thickness of sheath Specified value	Mean overall diameter Upper limit Informative value	Minimum insulation resistance at 20 °C	Minimum insulation resistance at 90 °C
mm ²	mm	mm	mm	MΩ.km	MΩ.km
1 × 1,5	0,7	0,8	5,4	860	0,86
1 × 2,5	0,7	0,8	5,9	690	0,69
1 × 4	0,7	0,8	6,6	580	0,58
1 × 6	0,7	0,8	7,4	500	0,50
1 × 10	0,7	0,8	8,8	420	0,42
1 × 16	0,7	0,9	10,1	340	0,34
1 × 25	0,9	1,0	12,5	340	0,34
1 × 35	0,9	1,1	14,0	290	0,29
1 × 50	1,0	1,2	16,3	270	0,27
1 × 70	1,1	1,2	18,7	250	0,25
1 × 95	1,1	1,3	20,8	220	0,22
1 × 120	1,2	1,3	22,8	210	0,21
1 × 150	1,4	1,4	25,5	210	0,21
1 × 185	1,6	1,6	28,5	200	0,20
1 × 240	1,7	1,7	32,1	200	0,20

Table 2 — Tests for cables to EN 50618

1	2	3	4	5	6	7
Ref No	Test	Unit	Test method described in		Requirements	Category of test
			EN	Clause		
1	Electrical tests					
1.1	Measurement of the resistance of conductor		50395	5		S
1.1.1	Values to be obtained, max.				Not to be exceeded as stated in EN 60228	
1.2	Voltage test on completed cable with a.c. or d.c.		50395	6		S
1.2.1	Test conditions:					
	- minimum length of the sample	m			20	
	- minimum period of immersion in water	h			1	
	- temperature of the water	°C			20 ± 5	
1.2.2	Voltage applied (a.c.) or Voltage applied (d.c.)	kV kV			6,5 15	
1.2.3	Duration of application of voltage, minimum	min			5	
1.2.4	Result to be obtained				No breakdown	
1.3	Check for absence of faults on the insulation (or on completed cable)		62230	Annex A		R
1.3.1	Result to be obtained				No fault shall be detected	
1.4	Measurement of insulation resistance		50395			S
1.4.1	Cables at 20 °C			8.1		
1.4.1.1	Test conditions:					
	- length of sample	m			5	
	- minimum period of immersion in water	h			2	
	- temperature of the water	°C			20	
1.4.1.2	Result to be obtained	MΩ.km			Min. as stated in Table 1.	
1.4.2	Cables at 90 °C			8.1		
1.4.2.1	Test conditions:					
	- length of sample	m			5	
	- minimum period of immersion in hot water	h			2	
	- temperature of the water	°C			90	

1	2	3	4	5	6	7
Ref No	Test	Unit	Test method described in		Requirements	Category of test
			EN	Clause		
1.4.2.2	Result to be obtained	MΩ.km			Min. as stated in Table 1.	
1.5	Long term resistance of insulation to d.c.		50395	9		T
1.5.1	Test conditions: - length of sample - duration of test - water temperature - d.c. voltage applied	m h °C kV			5 240 85 ± 5 1,8	
1.5.2	Result to be obtained				No breakdown and no signs of damage	
1.6	Surface resistance of sheath		50395	11		T
1.6.1	Test conditions: - voltage applied, d.c. - duration of test	V min			100 to 500 1	
1.6.2	Result to be obtained	ohm			≥ 10 ⁹	
2	Constructional and dimensional tests					
2.1	Conductor					T
2.1.1	Maximum diameter of wire in conductor	mm			Not to be exceeded as stated in 6.1 of EN 60228:2005	
2.1.2	Checking continuity of tin		This standard	5.1.1	No visible gaps	
2.2	Insulation					S
2.2.1	Insulation thickness	mm	50396	4.1	Not less than stated in 5.2.3 of this standard	
2.3	Sheath					S
2.3.1	Sheath thickness	mm	50396	4.2	Not less than stated in 5.3.3 of this standard	
2.4	Ovality					S
2.4.1	Ovality value	%	50396	4.4.2	As stated in 7.3.3 of this standard	
2.5	Sheath colour					S
2.5.1	Visual examination				As stated in 7.3.1 of this standard	
2.6	Sheath marking					S
2.6.1	Visual examination and measurement				As stated in 7.3.2 of this standard	

1	2	3	4	5	6	7
Ref No	Test	Unit	Test method described in		Requirements	Category of test
			EN	Clause		
3	Insulation material				As stated in Table B.1 of this standard	T
4	Sheath material				As stated in Table B.1 of this standard	T
5	Compatibility test		60811-401			T
5.1	Test conditions:					
	- duration of test	h			168	
	- temperature	°C			135 ± 2	
5.2	Result to be obtained				As stated in Table B.1 of this standard	
6	Cold impact test		60811-506			T
6.1	Test conditions				As stated in Annex C of this standard	
6.2	Results to be obtained				No cracks	
7	Cold bending test		60811-504			T
	Cable diameter ≤ 12.5mm					
7.1	Test conditions:					
	- conditioning duration	h			16	
	- temperature	°C			-40 ± 2	
7.2	Result to be obtained				No cracks	
8	Cold elongation test		60811-505			T
	Cable diameter > 12.5mm					
8.1	Test conditions:					
	- conditioning duration	h			16	
	- temperature	°C			-40 ± 2	
	Result to be obtained				Min. 30 % elongation	
9	Ozone resistance on complete cable					T
9.1	Method A		60811-403			
	- temperature	°C			25 ± 2	
	- duration	h			24	
	- ozone concentration (by volume)	%			(250 to 300) × 10 ⁻⁴	
	Or:					

1	2	3	4	5	6	7
Ref No	Test	Unit	Test method described in		Requirements	Category of test
			EN	Clause		
9.2	Method B		50396	8.1.3		
	- temperature	°C			40 ± 2	
	- relative humidity	%			55 ± 5	
	- duration	h			72	
	- ozone concentration (by volume)	%			(200 ± 50) × 10 ⁻⁶	
9.3	Result to be obtained				No cracks	
10	Weathering/UV resistance on sheath					T
10.1	Test conditions				As stated in Annex E of this standard	
10.2	Result to be obtained				As stated in Annex E of this standard	
11	Dynamic penetration test					T
11.1	Test conditions				As stated in Annex D of this standard	
11.2	Result to be obtained				As stated in Annex D of this standard	
12	Damp heat test		60068-2-78			T
12.1	Test conditions:					
	- temperature	°C			90	
	- duration	h			1 000	
	- relative humidity min.	%			85	
	- reconditioning period	h			16 to 24	
12.2	Results to be obtained on the sheath:					
	- for tensile strength, variation maximum	%			-30 ^a	
	- for elongation at break, variation maximum	%			-30 ^a	
13	Shrinkage test on sheath		60811-503			T
13.1	Test conditions:					
	- temperature	°C			120	
	- duration	h			1	
	- length of sample	mm			300	
13.2	Results to be obtained:					
	- maximum shrinkage	%			2	

1	2	3	4	5	6	7
Ref No	Test	Unit	Test method described in		Requirements	Category of test
			EN	Clause		
14	Test for vertical flame propagation on complete cable		60332-1-2			S
14.1	Result to be obtained		60332-1-2	Annex A	Pass	
15	Smoke emission of complete cable		61034-2			T
15.1	Result to be obtained - light transmittance, min.		61034-2		60 %	
16	Assessment of halogens for all non-metallic materials		50525-1			T
16.1	Result to be obtained		50525-1	Annex B	Comply with requirements of Annex B of EN 50525-1:2011	
^a No positive value of variation defined.						

Annex A (normative)

Guide to use – Use of cables for PV systems

General information given in EN 50565-1 (Guide to Use for low voltage harmonized cables) shall be used.

In addition the following specific information shall be taken into account for the products specified in this standard.

The nominal d.c. voltage rating of the cables is 1,5 kV, both between conductors as well as between conductors and earth. The maximum permitted operating d.c. voltage of the systems, in which the cables specified in this standard are applied, shall not exceed 1,8 kV.

The a.c. voltage rating of the specified cables is 1/1 kV (U_0/U). The rated voltage in an d.c. system, is expressed by the combination of two values U_0/U , expressed in (k)volts, where:

- U_0 is the r.m.s. value between any insulated conductor and earth;
- U is the r.m.s. value between any two phases.

Table A.1 — Intended use of cables for PV systems (environmental conditions)

Code designation	H1Z2Z2-K
Shape of cable	Round
Conductor construction	K
<u>1 DUTY</u> ^a	
1.4 Heavy	+
<u>2 PRESENCE OF WATER</u>	
2.1 Condition AD 7 ^b	+
<u>3 CORROSIVE OR POLLUTING SUBSTANCES</u>	
3.1 Condition AF 3 ^b	+
<u>4 IMPACT</u>	
4.1 Condition AG 2 ^b	+
<u>5 VIBRATIONS</u>	
5.1 Condition AH 3 ^b	+
<u>6 FLORA</u>	
6.1 Condition AK 2 ^b	-
<u>7 FAUNA</u>	
7.1 Condition AL 2 ^b	-
<u>8 OUTDOOR USE</u> ^c	
8.1 Condition AN 3	+
8.2 Permanent ^d	+
<u>9 FREQUENT FLEXING</u>	
	-
<u>10 FREQUENT TORSION</u>	
	-
"+" = acceptable "-" = not suitable a See EN 50565-1:2014, Annex B, for definitions. b See HD 60364-5-52 for definitions. c Only for the relevant duty classification given in No. "1 DUTY". d See EN 50565-1:2014, Annex A, for definitions.	

Table A.2 — Recommended use of cables for PV systems

1	2	3
Construction	Recommended use	Comments
Cables for PV-systems H1Z2Z2-K	Intended for use in PV installations e.g. acc. to HD 60364-7-712. They are intended for permanent use outdoor and indoor, for free movable, free hanging and fixed installation. Installation also in conduits and trunkings on, in or under plaster as well as in appliances. Suitable for the application in/at equipment with protective insulation (protection class II). They are inherently short-circuit and earth fault proof acc. to HD 60364-5-52.	For recommended bending radii see EN 50565-1:2014, Table 3 Max. storage temperature: + 40 °C Min. temperature for installation and handling: - 25 °C

Table A.3 — Current carrying capacity of PV cables

Nominal cross sectional area mm ²	Current carrying capacity according to method of installation		
	Single cable free in air A	Single cable on a surface A	Two loaded cables touching, on a surface A
1,5	30	29	24
2,5	41	39	33
4	55	52	44
6	70	67	57
10	98	93	79
16	132	125	107
25	176	167	142
35	218	207	176
50	276	262	221
70	347	330	278
95	416	395	333
120	488	464	390
150	566	538	453
185	644	612	515
240	775	736	620
Ambient temperature: 60 °C (see Table A.4 for other ambient temperatures) max. conductor temperature: 120 °C.			
NOTE The expected period of use at a max. conductor temperature of 120 °C and at a max. ambient temperature of 90 °C is limited to 20 000 h.			

Table A.4 — Current rating conversion factors for different ambient temperatures

Ambient temperature °C	Conversion factor
up to 60	1,00
70	0,92
80	0,84
90	0,75

Groups

For installation in groups the reduction factors for current rating according to HD 60364-5-52:2011, Table B.52.17 shall apply.

Short-circuit-temperature

The permitted short-circuit-temperature is 250 °C referring to a period of 5 s.

Annex B (normative)

Requirements for insulation and sheathing materials

Table B.1 — Requirements for insulation and sheathing materials

1	2	3	4	6	7
Ref No.	Tests	unit	Test Method standard	Type of compound	
				insulation	sheath
1	Mechanical characteristics				
1.1	Properties before ageing ^c		EN 60811-501		
1.1.1	Values to be obtained for tensile strength - median, min.	N/mm ²		8.0	8.0
1.1.2	Values to be obtained for the elongation at break - median, min.	%		125	125
1.2	Properties after ageing in oven		EN 60811-401		
1.2.1	Test conditions: ^c - temperature - duration of treatment	°C h		150 ± 2 7x24	150 ± 2 7x24
1.2.2	Values to be obtained for tensile strength - variation, maximum	%		-30 ^a	-30 ^a
1.2.3	Values to be obtained for the elongation at break - variation, maximum	%		-30 ^a	-30 ^a
1.3	Hot set test ^c		EN 60811-507		
1.3.1	Test conditions: - temperature - time under load - mechanical stress	°C min N/cm ²		250 ± 3 15 20	250 ± 3 15 20
1.3.2	Values to be obtained - elongation under load, max. - permanent elongation after cooling, max.	% %		100 25	100 25
1.4	Thermal endurance		EN 60216-1 and EN 60216-2		
1.4.1	Test conditions: ^c Elongation at break shall be performed. - temperature index corresponding to 20 000 h - elongation at break, min.	%		≥ 120 50	≥ 120 50
1.5	Cold elongation test		EN 60811-505		

1	2	3	4	6	7
Ref No.	Tests	unit	Test Method standard	Type of compound	
				insulation	sheath
1.5.1	Test conditions: ^c - temperature	°C		-40 ± 2	-40 ± 2
	- duration	h		^b	^b
1.5.2	Values to be obtained: - elongation at break, min.	%		30	30
1.6	Sheath resistance against acid and alkaline solution		EN 60811-404		
1.6.1	Test conditions: - acid solution: N-Oxalic acid - alkaline solution: N-Sodium hydroxide - temperature	°C			23
	- duration of treatment	h			7x24
1.6.2	Values to be obtained for tensile strength - variation, maximum	%			± 30
1.6.3	Values to be obtained for the elongation at break, min.	%			100
1.7	Compatibility test		EN 60811-401, 4.2.3.4		
1.7.1	Test conditions: - temperature	°C		135 ± 2	135 ± 2
	- duration of treatment	h		7x24	7x24
1.7.2	Values to be obtained for tensile strength - variation, maximum	%		± 30	-30 ^a
1.7.3	Values to be obtained for the elongation at break - variation, maximum	%		± 30	-30 ^a

^a No positive value for variation defined.

^b See test method in column 4.

^c This test shall be performed on test samples of insulation and sheath compound obtained from completed cables.

Annex C (normative)

Cold impact test

The cold impact test shall be performed at -40 °C according to EN 60811-506, but the mass of hammer, the mass of steel intermediate piece and height shall comply with Table C.1.

Table C.1 — Parameters for cold impact test

Cable diameter (D) mm	Mass of hammer g	Mass of steel intermediate piece g	Height mm
$D \leq 15$	1 000	200	100
$15 < D \leq 25$	1 500	200	150
$D > 25$	2 000	200	200

The cable shall be inspected with normal or corrected vision without magnification. No cracks shall be determined.

Annex D (normative)

Dynamic penetration test

A test apparatus suitable for pull testing (or an equivalent apparatus) shall be operated in pressure modus and shall be equipped with a measuring device which is able to record the force of penetration of a spring-steel-needle through the insulation or sheath of a completed cable (see Figure D.1; the test is made with the side of the needle not with the point of the needle). A circuit with low voltage, which is interrupted at the moment when the needle penetrates the sheath and the insulation and makes contact with the conductor, shall be added.

The test shall be performed at room temperature. The force applying to the needle shall be increased continuously with 1 N/s until contact with the conductor has been made. Four tests on each sample shall be performed and the force at the moment of contact shall be recorded. After each test the sample shall be moved forward and shall be turned clockwise for 90°.

The mean value of the four test results shall not be less than the minimum value F_{\min} determined with the following formula

$$F_{\min} = 150 \sqrt{d_L}$$

with

F_{\min} value of test force in N;

d_L diameter of conductor according to Table 2 of EN 60719, in mm.

Dimensions in millimetres

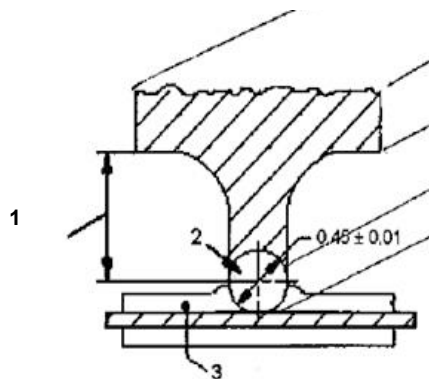

Key

- 1 shoulder with sufficient depth for testing the insulation
- 2 needle of spring steel
- 3 sample

Figure D.1 — Arrangement for dynamic penetration test

Annex E (normative)

Weathering/UV resistance test

This test is to determine the UV stability of the sheathing material of the cable in the condition as manufactured. This is done by means of measuring elongation at break in the condition as manufactured and after exposure to ultraviolet light and water.

Samples shall be selected, prepared and tested in accordance with EN 60811-501.

Samples shall be exposed to UV light in accordance with the requirements of EN 50289-4-17, method A, for 720 h (360 cycles).

NOTE Additional information on weathering/UV resistance testing can be found in EN ISO 4892-1:2000 and EN ISO 4892-2:2006.

After the exposure, the test specimens shall be removed from the equipment and conditioned at ambient temperature for at least 16 h.

Five exposed specimens and five not exposed specimens are to be tested separately and in close succession for tensile strength and elongation at break. The respective median values are to be calculated from the five tensile strength and elongation at break values obtained for the conditioned specimens and are to be divided by the median values of the five tensile strength and elongation at break values obtained for the unconditioned specimens.

It is required that the tensile strength and elongation at break after 720 h (360 cycles) of exposure is at least 70 % of the values measured on not exposed specimens.

Bibliography

- [1] HD 60364 (all parts), *Electrical installations of buildings (IEC 60364, all parts)*
- [2] EN ISO 4892-1, *Plastics – Methods of exposure to laboratory light sources – Part 1: General Guidance (ISO 4892-1)*
- [3] EN ISO 4892-2, *Plastics – Methods of exposure to laboratory light sources – Part 2: Xenon-arc lamps (ISO 4892-2)*